

NOTES:

1. METAL IS UNS S31603/AISI 316L PER ASTM A276.
2. MAXIMUM FLUID LOSS = <0.025 ML (0.39 DROP).
3. MAXIMUM WORKING PRESSURE = 20 BAR (290 PSI).
4. BURST PRESSURE RATING = 80 BAR (1160 PSI).
5. TEMPERATURE RATING = -40°C TO 120°C (-40°F TO 248°F).
6. A BLUE OR RED RING IS LOCATED HERE.
7. FORCE TO CONNECT UNDER NO PRESSURE = 38 N (8.5 LBF).
8. MAXIMUM FLOW RATE = 8.6 LPM (2.3 GPM).
9. FLOW COEFFICIENT = 0.25.

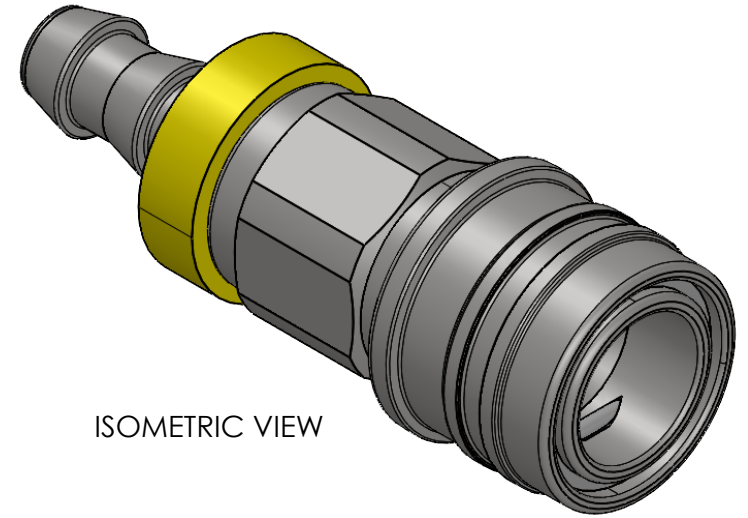

ISOMETRIC VIEW

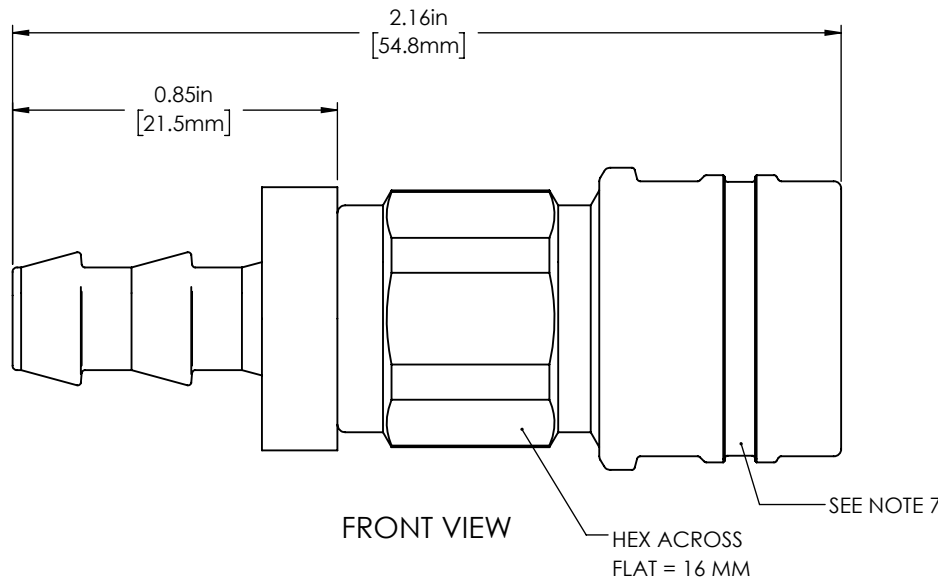

FRONT VIEW

HEX ACROSS
FLAT = 16 MM

SEE NOTE 7

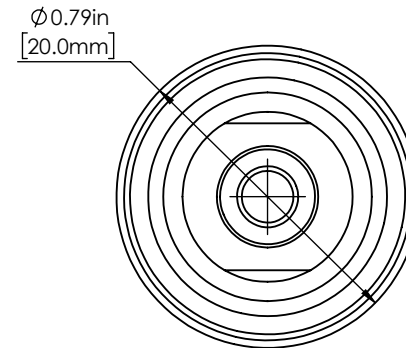

RIGHT END VIEW

UNLESS OTHERWISE SPECIFIED:
DIMENSIONS ARE IN INCHES.
BREAK ALL SHARP EDGES .005 MAX.
TOLERANCES:
ANGULAR: ±0.5°
TWO PLACE DECIMAL: ±0.010"
THREE PLACE DECIMAL: ±0.005"
DIAMETERS: 0.006" TIR ABOUT Q
MAXIMUM SURFACE ROUGHNESS: Ra 90 µin

MATERIAL
SEE NOTE 1

HEAT TREATMENT
N/A

SURFACE FINISH
N/A

	NAME	DATE
DRAWER	TONY HEPP	6-15-2026
ENG APPR.	TONY HEPP	6-15-2026
MFG APPR.	MIKE RUSSELL	6-16-2026



2324 W. Battlefield Rd. Springfield, MO 65807

TITLE:
UNIVERSAL QUICK DISCONNECT
COUPLER, BODY SIZE 02 / 1/8",
FEMALE SOCKET,
1/4" ID PUSH-ON HOSE BARB

SIZE A	DWG. NO. UQD02F-S02H	REV A
------------------	-------------------------	-----------------

THEORETICAL WEIGHT 1.73 OZ	SCALE:	SHEET 1 OF 1
-------------------------------	--------	--------------

PROPRIETARY AND CONFIDENTIAL

THE INFORMATION DISCLOSED IN THIS DOCUMENT IS PROPRIETARY TO FOSTER MFG. CO. AND MAY NOT BE USED FOR MANUFACTURE OR ANY OTHER PURPOSE WITHOUT THE WRITTEN CONSENT OF FOSTER MFG CO.